

AIREX and AIREX MINOR

FULLY AUTOMATIC AIR ESCAPE VALVES WITH OVERFLOW PROTECTION

TOLERATE ANTIFREEZE

RELIABLE

EASILY FITTED

ROBUST DESIGN

AIREX and AIREX MINOR Automatic Air Escape Valves have for more than 25 years proved to be invaluable fittings in a well functioning central heating system. During the whole of this period the valves have been continuously developed and improved in order to meet the ever increasing demands placed on components in modern central heating systems.

An automatic air escape valve not only keeps the system free from air but also collects any impurities such as solid particles there may be in the circulation water. Dirt in the system can gradually lead to functional failure — either the valve becomes blocked or its sealing function is prevented so that it starts to leak.

AIREX and AIREX MINOR now have an automatic overflow protection system which only allows a very small quantity of water to leak out — just sufficient to indicate that there is a fault in the system but not enough to cause any damage.

Tested by the National Swedish Institute for Materials Testing — Test Certificate No. 7912,96 issued on 10th April 1979.

AIREX and AIREX MINOR are not only suitable for use in central heating systems, but in all other applications where venting required. Since they are manufactured entirely of chromed brass and the rubber components are made of nitrile rubber (SIS 162630-705), they can also be used with liquids other than water providing that the components in the system concerned are able to withstand the liquid.

AIREX and AIREX MINOR are supplied complete with shut-off valve to be removed for cleaning without having to drain off the whole system.

All parts are subjected to rigorous production control — the floats are tested for at least 24 hours at a pressure of 8 bars and each valve is individually tested before being packed for delivery.



AIREX

Technical Data

Max. working pressure	8 bars
Burst pressure	14 bars
Max. venting capacity	1 bar/750 litres/h 3 bars/1900 litres/h 6 bars/3400 litres/h
Max. operating temperature	120 °C
Dimensions	HxD 104/104 mm
Height mcl. shut-off valve	140 mm
Connection	10, female thread
Weight md. shut-off valve	0,4 kg

AIREX MINOR

Technical Data

Max. working pressure	4 bars
Burst pressure	8 bars
Max. venting capacity	1 bar/305 litres/h 2 bars/500 litres/h 3 bars/700 litres/h
Max. operating temperature	120 °C
Dimensions	HxD 85/72 mm
Height md. shut-off valve	114 mm
Connection	10, female thread
Weight mcl. shut-off valve	0,3 kg

Subject to design modifications.

AIREX and AIREX MINOR

AUTOMATIC AIR ESCAPE VALVES

FITTING DIRECTIONS

The valve must be placed vertically and can be fitted on both high and low level lines and on appliances which need to be vented.

The accompanying shut-off valve is screwed on the pipe connection. The air escape valve is then screwed on (note the fibre washer — no hemp and linseed oil to be used). Open the shut-off valve and the automatic venting comes into operation.

Do not place the valve where a risk of freezing could occur.

AIREX and AIREX MINOR can also be used for venting lines and appliances for other liquids than water providing that they do not attack rubber and/or fibre parts.

When fitting out of doors or where the valve could be subjected to water spray, the overflow protection system should be placed out of function by removing the fibre washers under the cap (6).

SERVICE AND MAINTENANCE

If the valve does not function due to dirt having collected in it or is damaged in any other way, it can be taken apart for cleaning and/or repair as follows:

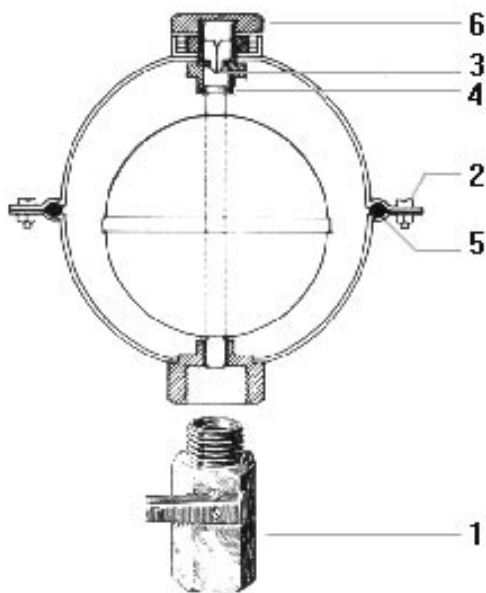

AIREX

Close the shut-off valve (1) and unscrew the air escape valve.

Take apart the valve by removing the 11 screws (2) which hold the valve body halves together.

Clean all parts and check the nozzle (3) and rubber plug (4) on the float. Replace any damaged parts with new ones.

Check that the float seals properly by shaking it and listening for any water splash in it.

Check the 0-ring (5) between the valve body halves - replace with a new one if damaged - and assemble the valve body. Make sure that all the 11 screws (2) are tightened evenly.

If water has leaked out from the valve the overflow protection function must be reset. Screw off the cap (6) and replace all the fibre washers under it with new ones. Note that only genuine washers should be used, otherwise the function cannot be guaranteed.

Screw the air escape valve on the shut-off valve — do not forget the fibre washer — open the shut-off valve and check the function.

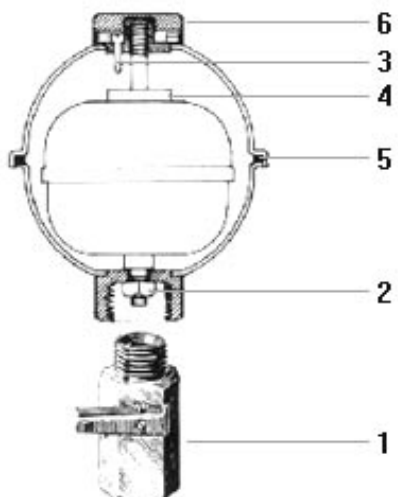

AIREX MINOR

Close the shut-off valve (1) and unscrew the air escape valve.

Take apart the valve by unscrewing the nut (2) with an 8 mm socket spanner.

Clean all parts and check the nozzle (3) and rubber washer (4) on the float. Replace any damaged parts with new ones.

Check that the float seals properly by shaking it and listening for any water splash in it.

Check the rubber gasket (5) between the valve body halves — replace with a new one if damaged — and assemble the valve.

If water has leaked out from the valve the overflow protection function must be reset. Screw off the cap (6) and replace the fibre washers under it with new ones. Note that only genuine washers should be used, otherwise the function cannot be guaranteed.

Screw the air escape valve on the shut-off valve — do not forget the fibre washer — open the shut-off valve and check

the function.

AB FRENCO - Box 57 - S 772 22 GRÄNGESBERG, SWEDEN

Telephone int+46 240 212 80 - Telefax int+46 240 212 68